

Coil-Type STEAM GENERATORS

Equipment helps realize significant fuel savings



In an article published in the September 1999 issue of *HPAC Engineering*,¹ I discussed using coil-type steam generators to supplement (or, in some instances, even replace) firetube (or natural-circulation watertube) boilers in traditional heating-plant applications. In that article, which offers a thorough description of forced-circulation technology, primary selection criteria were identified. Although briefly mentioned, the fuel savings associated with this technology were not addressed in detail.

Nearly two years later, following a dramatic increase in fuel prices, the fast-startup characteristics of coil-type steam generators are even more significant than before. In 1973, the average cost of natural gas delivered to electric-utility consumers was 38 cents per thousand cubic feet.² That cost increased nearly tenfold over the next decade, reaching \$3.70 per thousand cubic feet in 1984.² It then began a gradual decline to an average of \$2.43 in 1999.² Last year, however, prices of energy hit record highs, with the cost of natural gas to electric utilities reaching \$4.46 in June 2000.²

The forecast for 2002 is for gas at the wellhead to sell for \$4.57 per thousand cubic feet, which will translate to a cost to electric utilities of \$4.99 per million

Rick Fischer/Masterfile

Btu.³ So for the short term at least, the price of natural gas will be a major concern to users of gas-fired steam boilers. And, of course, No. 2 oil is following the same trends as natural gas, with the average wholesale cost of No. 2 heating oil expected to be 87 cents per gallon this year.³

For the typical industrial user of natural gas or No. 2 fuel oil, this translates to a cost of 50 to 60-plus cents per therm (100,000 Btu). At this price level, alternative technologies that offer improvements in efficiency—even if initially more expensive—must be examined. The coil-type steam generator is one such technology. Along with alternative technologies, steam-system maintenance and its impact on energy conservation must be examined.

At the current price levels of fuel, it is imperative to properly maintain existing equipment and components. For example, although much has been written on the subject, and all steam-boiler users know (or should know) the consequences if it is not practiced, proper steam-trap maintenance still is a significant problem.⁴ At 60 cents per therm, the cost of 1,000 lb of steam (based on a boiler efficiency of 80 percent) is approximately \$7.29, as shown below:

$$1,000 \text{ lb steam} \times (33,520 \text{ Btu/h} \div 34.5 \text{ lb per hour steam}) = 971,594 \text{ Btu}$$

$$(971,594 \text{ Btu} \div 1 \times 10^5 \text{ Btu per therm}) \times 60 \text{ cents per therm} \div 0.80 = \$7.29$$

Using the data in French's Table 1,⁴ and substituting \$7.29 (for fuel only) in his calculations, which were based on an average cost of \$5 per 1,000 lb of water, feedwater treatment, and fuel, the results are dramatic. For example, French demonstrated that almost half-a-million pounds of dry steam per month can

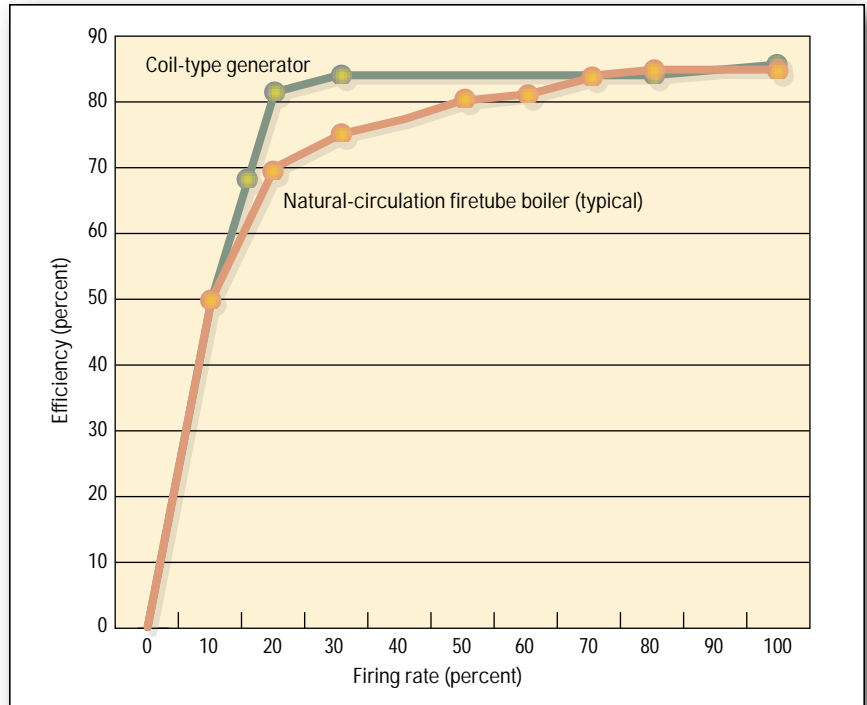

FIGURE 1. Efficiency of coil-type steam generators and natural-circulation firetube boilers over firing range.

be lost through a $\frac{1}{8}$ -in. sharp-edged orifice. At today's costs, this results in an economic loss of more than \$40,000 per year.

So how can steam-boiler users determine if they should replace an older firetube boiler with another type of firetube boiler or with a coil-type steam generator? And what about the potential for substantial savings of a new application? Can coil-type steam generators better realize those savings? Obviously, users first must determine if: (1) a coil-type steam generator is suitable for their application and, (2) if so, the economic payback justifies that selection.

As mentioned above, coil-type steam generators are most effective in heating applications in which one or more of the following conditions exist:

- Additional steam capacity is needed, and available floor space, headroom, and/or physical access is limited or restricted.

- There are significant cyclical or seasonal load fluctuations.

- The operation experiences short-duration load swings.

- The boiler operation is in a standby mode.

So, assuming something other than a 24/7, constant-load condition, how can a user determine if a steam generator is economically feasible?

The first consideration, of course, usually is the initial capital cost of the equipment. The "typical" selling price of a coil-type steam generator generally is higher than that of a firetube boiler. However, the installation cost may be somewhat lower because steam generators often can be disassembled and rigged through existing access ways, reducing or eliminating the need for demolition and reconstruction. And, unlike most other field-erected boilers, coil-type steam generators can be reassembled without welding, eliminating the need for code

COIL-TYPE STEAM GENERATORS

welders and fire-watch provisions.

The most significant savings with a steam generator, though, may be realized in applications in which all or part of the boiler operation is in a standby mode. Because of its relatively long startup time, the firetube boiler generally will be kept in a “hot” standby condition by maintaining low fire. This results in fuel consumption without the effective use of the energy produced. With its fast steaming characteristics—typically, cold startup to full output in approximately five minutes—the coil-type steam generator, on the other hand, can be started only as needed. Because most existing firetube-boiler steam-heating plants will have at least five minutes of reserve steam in their system, this “boiler-on-demand” concept can be practical even for critical steam requirements. And the coil-type steam generator’s inherent immunity from failures caused by thermal shock ensures long life even with frequent starts and stops.

Suppose we have three 400-bhp firetube boilers in an older heating plant with a 16-week heating season. The boilers are configured so that two of them run while the third is in a low-fire “standby” mode. This third boiler operates in other than standby mode only 10 percent of the four-month heating season and has an average “fuel-to-steam” efficiency of 80 percent. The average ambient-heat losses from the shell only (“vessel losses”) are 5 percent. Just in making up for those ambient-heat losses, the standby boiler will waste more than \$12,000 per heating season, as shown below:

$$\begin{aligned}
 & 400 \text{ bhp} \times 33,520 \text{ Btu/h per bhp} \\
 & \div 0.80 \text{ efficiency} \times 0.05 \text{ average heat loss} \\
 & = 838,000 \text{ Btu/h} \\
 \\
 & 16 \text{ weeks} \times 7 \text{ days per week} \\
 & \times 24 \text{ hr per day} \times 90 \text{ percent} = 2,419 \text{ hr} \\
 \\
 & 838,000 \text{ Btu/h} \times 2,419 \text{ hr} \div 1 \\
 & \times 10^5 \text{ Btu per therm} \times 60 \text{ cents per therm} \\
 & = \$12,163
 \end{aligned}$$

With the list price of a 400-bhp coil-type steam generator in the range of \$80,000 (compared with \$60,000 for a firetube boiler), the payback in replacing the older firetube boiler in this scenario with a new coil-type steam generator will be less than two years. If you also consider installation costs, utilization of the other two boilers, and the maintenance implications of running a firetube boiler at low-fire hold for long periods of time, the quick-steaming advantage of the coil-type steam generator becomes even more attractive and the economic justification even more compelling.

Another application with much potential for fuel savings is a new installation in which a substantial portion of the steam load remains constant during continuous (24/7) operation, but still may exhibit swings during certain higher- or lower-use periods. In this case, the most-efficient configuration might call for coil-type

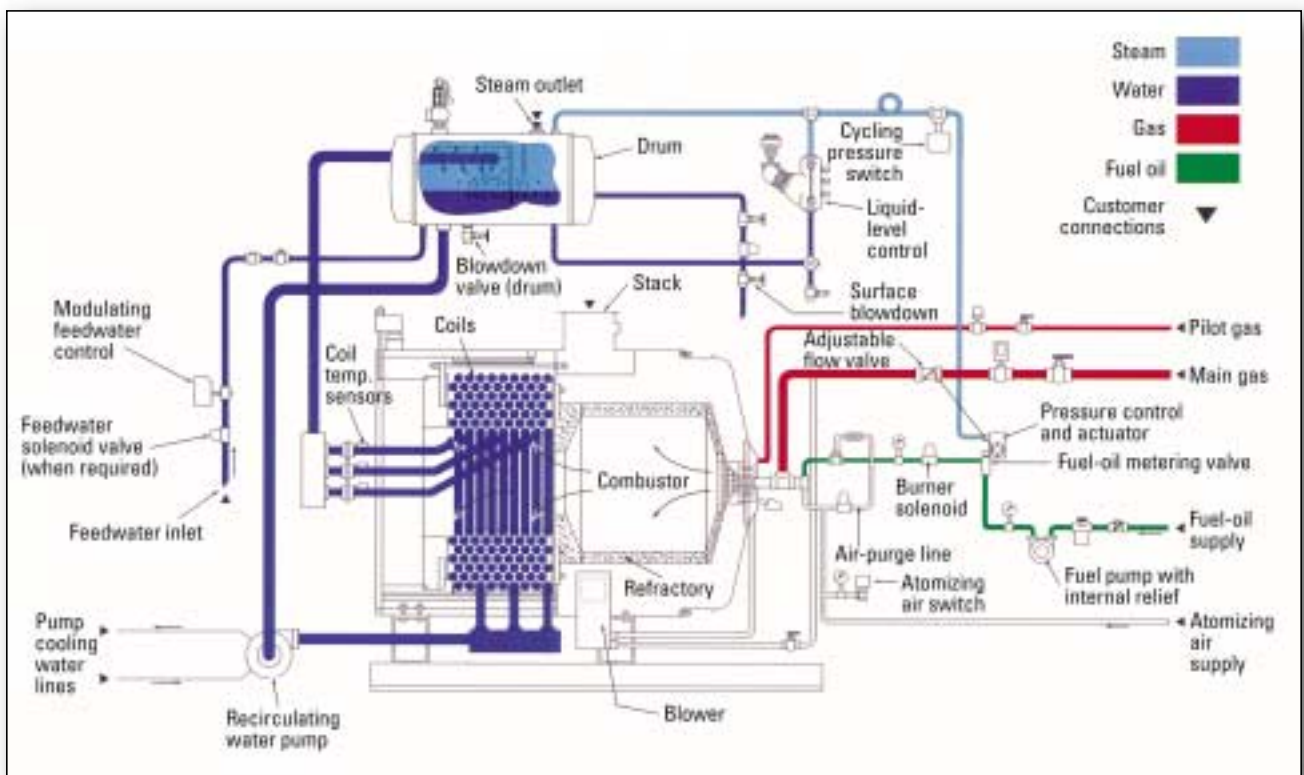

FIGURE 2. Flow diagram of a recirculating steam generator.

steam generators backing up fire-tube boilers. This would allow the boilers, which operate best at constant, full-design-load conditions, to be base loaded. The steam generators, with their fast response and full-modulation characteristics, then could handle the load swings for which they are designed. Because the efficiency curve of a coil-type steam generator essentially is flat over its full operating range (Figure 1), there is no economic penalty in this mode of operation (note that the area between the two curves represents fuel savings). Depending on the size and type of load, there also may be opportunities (such as during summertime operation) to take the firetube boilers off-line and carry the full load with only the steam generators. Often, this can result in both fuel savings and maintenance advantages.

To evaluate the potential benefits of the coil-type steam generator, it is important to understand the technology's theory of operation. Referring to Figure 2, water at saturation temperature is drawn from a steam drum and pumped through a set of nested, parallel-connected coils at several times the maximum desired steaming rate. The water then is carried to a steam lance and set of baffles and screens, where steam is released and effectively separated. Dry steam (greater than 99.5-percent dryness) is withdrawn from the drum, leaving a reservoir of heat-saturated feedwater. Because of its relatively low (2 to 3 percent) water content, the coil-type steam generator will be smaller, lighter, and faster in responding than will a comparably rated firetube boiler.

Moore⁵ suggested that many commercial and industrial two-boiler designs are best replaced with multiple-boiler systems. Perhaps the logical extension of that

concept—particularly for high-pressure steam applications—is a hybrid system configured with both conventional boilers and coil-type steam generators for optimum efficiency.

With energy costs at an all-time high and expected to remain there for a while, it is more important than ever to look at alternatives to the conventional boiler-plant design. The coil-type steam generator is only one such alternative. Innovative heat-recovery systems and other approaches to saving fuel also should be carefully examined.

References

- 1) Clark, L. September 1999. "Coil-Type Steam Generators for Heating Plant Applications." *HPAC Engineering*.
- 2) U.S. Energy Information Administration. October 2000. "Natural Gas Annual 1999."
- 3) Forecasts generated through simulation of the Short-Term Integrated Forecasting System. Data from Energy Information Administration databases supporting the following reports: "Petroleum Marketing Monthly," DOE/EIA-0380; "Natural Gas Monthly," DOE/EIA-

0130; "Monthly Energy Review," DOE/EIA-0035; and "Electric Power Monthly," DOE/EIA-0226.

4) French, S.A. March 2000. "Lighting a Fire Under Steam Trap Maintenance." *HPAC Engineering*.

5) Moore, J. July 1999. "Multiple-Boiler Sizing and Selection." *HPAC Engineering*.

About the author:

Larry S. Clark is eastern-region sales manager for Vapor Power Group in Niles, IL With a bachelor's degree in electrical engineering, he has 19 years of experience in all aspects of process equipment. He can be contacted at larryscl@aol.com. ■